

DISPLAY | Cabinet Displays

REFRIGERATED SHOWCASES UPRIGHT ► WHITE

RC 235

GAS R600a	H1 +1°C +10°C	B ENERGY CLASS	4 +30°C/55RH
LED			



DETAILS

Inner vertical LED light	Door handle	Digital control panel
--------------------------	-------------	-----------------------

GENERAL FEATURES

- 235 Lt. Upright refrigerated showcase (White Color)
- Flat glass with white frame and plastic basement
- Ventilated Cooling
- Automatic compressor cycle defrost
- Mechanical temperature control with digital display
- Interior LED light
- Toughened safety glass
- Adjustable shelves (N.4 shelf)
- N.4 fix support assembled under the basement
- Energy efficiency class: B

TECHNICAL SPECIFICATIONS

Capacity	235 L
Temperature	M2 (-1°C-+7°C)
Consumption	4.44 kWh/24h
Rated Power	380 W
Noise level	57 dB(A)
Net Weight	76 Kg
Gross Weight	87 Kg
External Dimensions (WxDxH mm)	515x485x1690
Internal Dimensions (WxDxH mm)	487x470x1120
Packaging dimensions (WxDxH mm)	580x540x1880
Loading quantities 20'/40'/40'HQ	39/82/82

PRODUCT DIMENSIONS

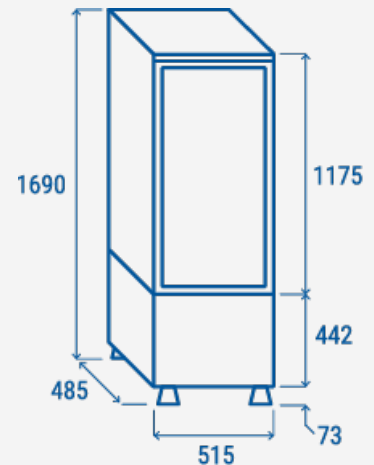

CERTIFICATION

CE RoHS

